



# ARIA VITALE

## HEAT RECOVERY VENTILATION UNIT



reddot winner 2023



DESIGN  
AWARD  
2023

**5** year  
warranty

Complete  
MVHR system

HEATPEX

> [heatpex.pl](https://heatpex.pl)

# HEATPEX ARIA

5 year  
warranty  
Complete  
MVHR system  
HEATPEX

Complete MVHR system  
pays off more

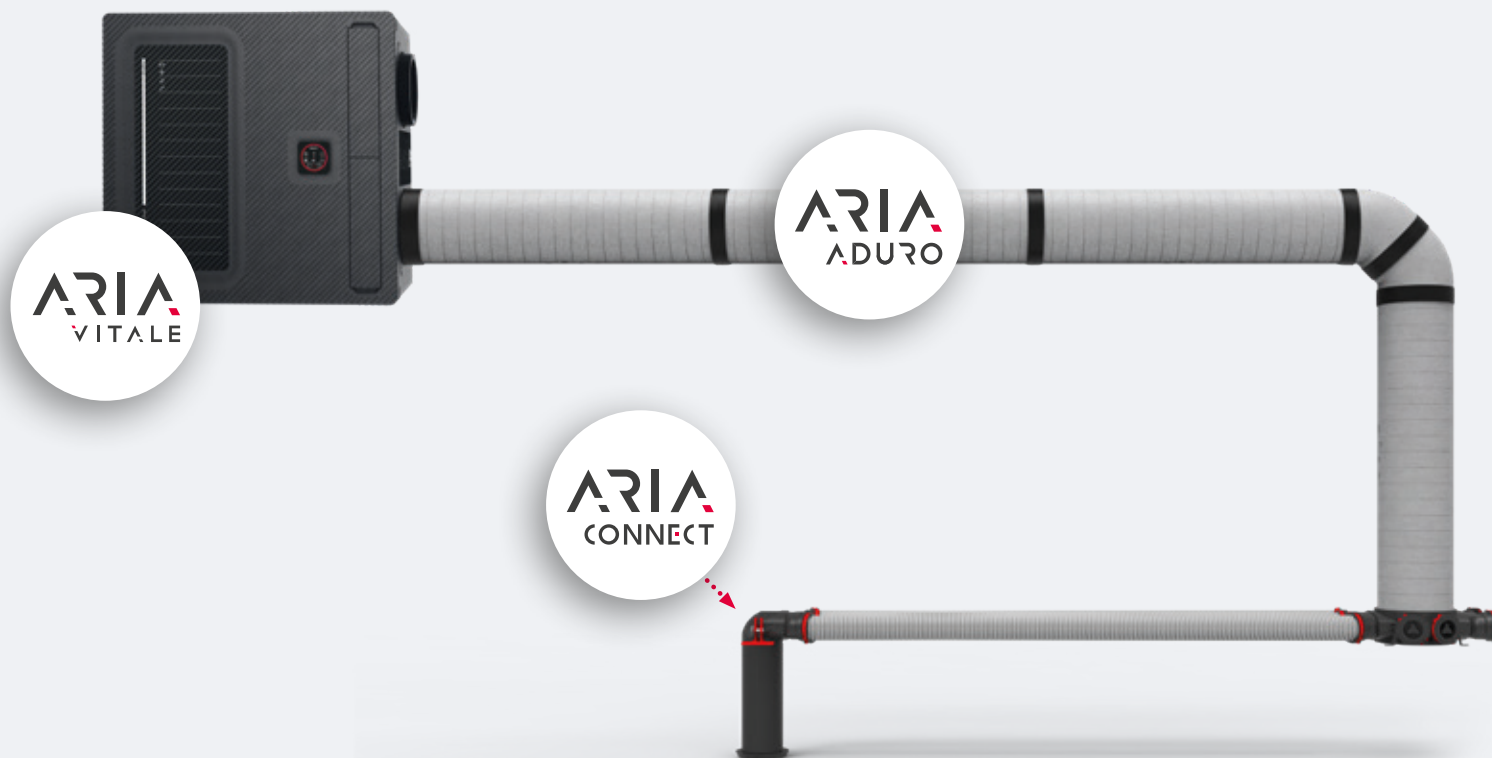

HEATPEX  
ARIA

ARIA  
VITALE

Heat  
recovery  
ventilation  
unit

+

ARIA  
ADURO

Insulated  
mass flow  
ductwork

+

ARIA  
CONNECT

Air distribution  
ducting system

FIND OUT MORE ABOUT HEATPEX'S COMPLETE MVHR SYSTEM ON OUR WEBSITE > [heatpex.pl](https://heatpex.pl)

# Contents

04	<b>Discover ARIA VITALE</b>
06	<b>Versatility &amp; simplicity of installation</b>
07	<b>Light-weight and compact device</b>
08	<b>Efficient and energy saving</b>
08	<b>Technical data</b>
09	<b>ARIA VITALE design features</b>
10	<b>Simple and intuitive controls</b>
11	<b>Removable control panel</b>
12	<b>Airtight and silent</b>
12	<b>Highest indoor air quality for You and your family</b>
13	<b>Enthalpy heat exchanger with antimicrobial and antiviral membrane</b>
14	<b>Hidden functionalities</b>
15	<b>Timeless design and high quality</b>



**ARIA**  
**VITALE**

Stylish, modern and efficient  
heat recovery ventilation unit



## Discover ARIA VITALE – stylish, modern and efficient heat recovery ventilation unit

Ventilation - key to a healthy home.

**Without proper ventilation,  
the house does not „breathe“.**

**That was the reason for HEATPEX to develop a device designed to ensure  
the highest air quality in your environment.**

ARIA VITALE MVHR unit has been designed in the spirit of the so-called “sustainable design”, i.e. where the choice of construction materials and technical solutions translate to durability, functionality and environmental aspect of the product. We have used the **best components** focusing on speed and simplicity of assembly and operation. The **innovative use of EPP material for the casing created a lightweight unit with high acoustic parameters and aesthetic appearance**, while reducing the environmental footprint.

ARIA VITALE is **the only such product on the market that can be mounted in 6 positions without compromising the efficiency of operations**. The installation and service are extremely easy. Simple and intuitive touch-screen control panel completes the picture.





reddot winner 2023



# ARIA VITALE

ARIA VITALE comes in **3 unique models (Silver, Gold, Platinum)** that can be easily matched to your needs. The MVHR unit contains a **great number of practical features and solutions** (Wi-Fi and wireless connectivity, glass touch-screen control panel, 100% by-pass, built-in pre-heater, mounting brackets), affecting the comfort and simplicity of everyday use.

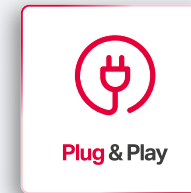
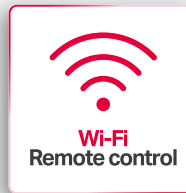

## SILVER

INCLUDES **Temperature sensor**

## GOLD

INCLUDES **Temperature sensor  
Humidity and CO<sub>2</sub> sensor**

## PLATINUM Enthalpy

INCLUDES **Temperature sensor  
Humidity and CO<sub>2</sub> sensor**

FLOW RATES **300 / 450 / 600 m<sup>3</sup>/h**



6 mounting options

# Versatility & simplicity of installation

ARIA VITALE is the only heat recovery unit on the market today with 6 installation configurations – **3 different positions** (floor, wall and ceiling) and **2 sides** – left or right.

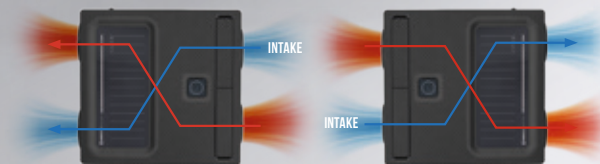

Left or right-hand installation for each version

# Light-weight and compact device

Easy installation due to low weight.

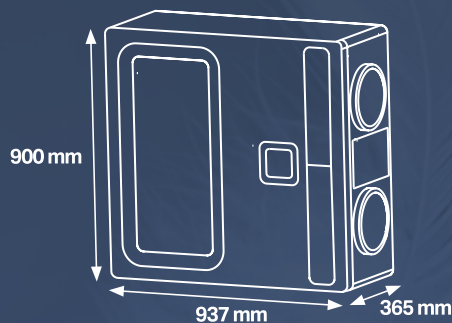

## 36 cm

Depth is only 36 cm

## 27,5 kg » 40 %

Weight

40% lower weight  
compared to most  
competitors

# ARIA ADURO COMPATIBLE



Epp connection  
stub pipes diameter  
**200 mm**



**The MVHR packaging contains custom-fit  
mounting brackets with built-in spirit levels.**

Additionally, to ease the installation, use a 1:1 mounting  
template (printed on the back of the cardboard box).



# Efficient and energy saving

The MVHR unit is characterised by high efficiency due to carefully **selected high quality heat exchangers of energy recovery up to 95%**.

In addition, the automated control unit used includes **weekly programming cycles**, which offers the **possibility of saving up to 30%** energy compared to manual operation. Quick main functions on the control panel, e.g. "holiday" minimise the unit's operation and provide further savings.

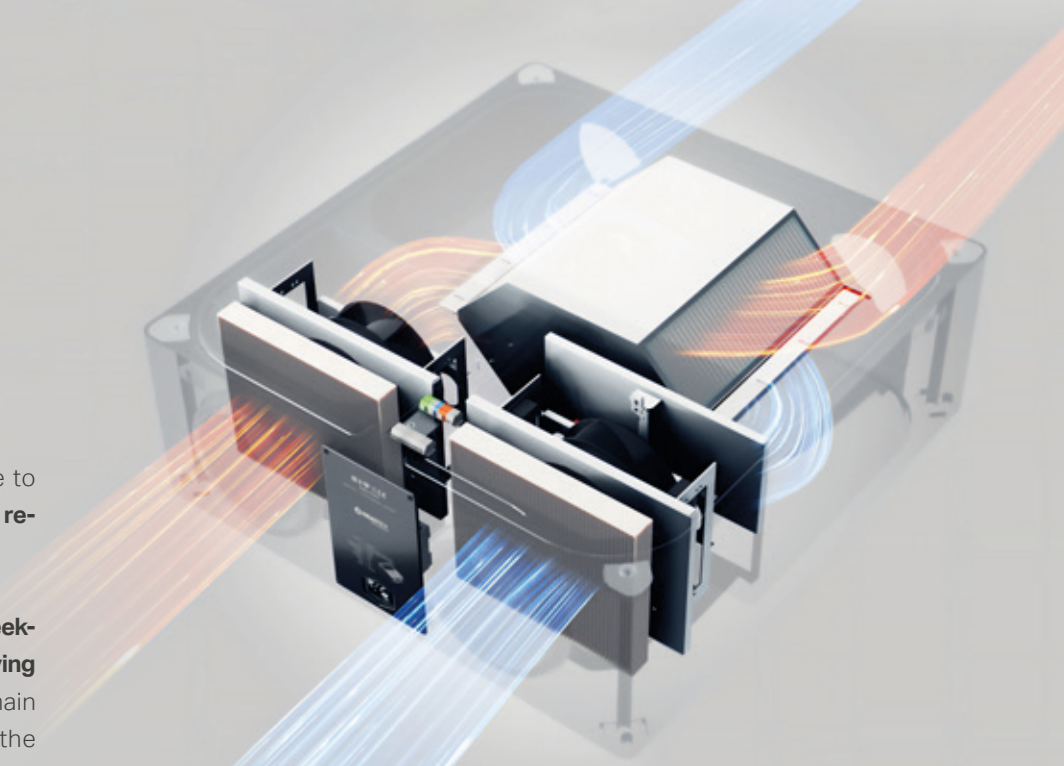

ENERGY EFFICIENCY UP TO

95%

ENERGY SAVING UP TO

30%

## TECHNICAL DATA

	ARIA VITALE 300	ARIA VITALE 450	ARIA VITALE 600		ARIA VITALE 300	ARIA VITALE 450	ARIA VITALE 600		
Maximum air flow	300 m <sup>3</sup> /h	450 m <sup>3</sup> /h	600 m <sup>3</sup> /h	Exchanger type	Recuperative plastic counterflow heat exchanger (Silver and Gold)				
Dimensions (h / w / d)	900 mm / 937 mm / 365 mm				Recuperative plastic counterflow enthalpy exchanger (Platinum)				
Mass	27,5 kg								
Inlet / outlet connections diameter	Ø 200			Energy consumption class	Cold	A+	A+	A+	
Drain connection diameter	Ø 10				Average	A+ / A (Platinum)	A	A / B (Platinum)	
IP rating	IP 40				Warm	E	E	E	
Power supply	230V / 50Hz			Factory fans settings	1	2	3	Party mode	Holiday mode
Fans rated power	2 x 45 W	2 x 95 W	2 x 177 W		35%	55%	75%	100%	25%
Preheater rated power	1000 W	2000 W	2000 W						
Filter class	ePM <sub>1</sub> , 70% (F7) – supply ePM <sub>10</sub> , 50% (M5) – extract			ARIA VITALE 300 [m <sup>3</sup> /h]	90	150	210	300	75
Sound power level through casing	44,4 dB(A)	50,9 dB(A)	53,4 dB(A)	ARIA VITALE 450 [m <sup>3</sup> /h]	135	225	315	450	113
				ARIA VITALE 600 [m <sup>3</sup> /h]	180	300	420	600	150





# ARIA VITALE design features



Comes **as standard** with

- ✓ Wi-Fi / wireless connection enabled
- ✓ Flat glass touch screen control panel
- ✓ Antifrost system with preheater
- ✓ Summer 100% by pass
- ✓ Mounting brackets and legs

# Simple and intuitive controls

## Pre-defined operating modes



**No expert knowledge is required** – the control panel is simple and intuitive. Pre-defined operating modes and **sensors that automatically react to unfavourable air conditions** optimise the unit's operation in terms of comfort, noise and energy consumption



**HOLIDAY MODE**



**PARTY MODE**



**AUTOMATIC MODE**

## Plug & play philosophy



The unit is designed according to Plug-and-Play philosophy, **pre-wired and pre-configured**. Once plugged in, it is immediately ready to use.



**Plug & Play**

## Advanced settings



**Aria myHOME app for advanced settings** (available through phone and computer). BMS / Smart Home connectivity available via **Modbus protocol**.

**ARIA**  
myHOME



**Wi-Fi**  
Remote control



DISCOVER ARIA VITALE MVHR UNIT

## Removable control panel

**Touch-screen control panel can be detached and fitted on the (living-room) wall.** A practical solution when the unit is installed in the attic. **Control panel dummy** and a power cable included.

### Mounting options

Wall **or** MVHR unit

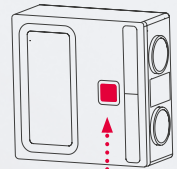

## Airtight and silent

ARIA VITALE heat recovery unit EPP casing and front panel have **the highest wall thickness on the market (50 mm)**. This allows the unit to operate quietly, especially at night time.

The applied wall thickness, combined with EPP connection stub pipes and the use of locks, **completely removes thermal bridges in the unit**, ensuring high tightness.

NOISE LEVEL  
OF ARIA VITALE  
300 m<sup>3</sup>/h IS ONLY

**44,4**  
dB(A)

MODEL	300 m <sup>3</sup> /h	450 m <sup>3</sup> /h	600 m <sup>3</sup> /h
NOISE LEVEL	<b>44,4</b> dB(A)	<b>50,9</b> dB(A)	<b>53,4</b> dB(A)



## Highest indoor air quality for You and your family

# Enthalpy heat exchanger with antimicrobial and antiviral membrane

Counterflow enthalpy exchanger with antibacterial and antiviral membrane – protection against viruses, including SARS-CoV-2, bacteria, mould, unpleasant odours and biological pollutants.



The durable polymer membrane ensures:

- high coefficient of **thermal conductivity** and **moisture transfer**
- resistance to **acids, alkalis** and **salts** (necessary to ensure stable operation)
- **tear and puncture** resistance
- excellent resistance to **environmental influences and temperature** fluctuations from -25°C to 50°C
- low **air permeability**

ARIA VITALE is equipped with **high-class cartridge filters** that effectively protect you and your loved ones against smog, bacteria, viruses and pollen.

EXTRACT AIR: **M5** ISO ePM<sub>10</sub> 50%

FRESH AIR: **F7** ANTI-SMOG FILTER **or** **M5** ACTIVATED CARBON FILTER

**F7** ISO ePM<sub>1</sub> 70% (ePM<sub>1</sub> 73,27% | ePM<sub>2,5</sub> 80,23% | ePM<sub>10</sub> 91,94%) **or** **M5** with activated carbon



# Hidden **functionalities**

The front panel of the unit hides several practical features

**Firstly, a washable glass memo board** allows the user to jot down important messages, e.g. the service engineer's phone number or filter replacement dates.

**Secondly, the control panel / display unit** located on the front is removable, and for the user's convenience, can be moved, for example, to a wall.

**Thirdly, the slots for changing filters** also act as a storage compartment for a **marker pen and TORX keys**.





## Timeless **design**

The **EPP (expanded polypropylene) material** used in the construction of the MVHR unit is characterised by its **low weight and high ductility**.

To add **more elegance and dynamism**, unique texture and additional grooves were introduced on the surface of the casing. This has **practically reduced the external surface area by half**, and large continuous sections with the same texture were eliminated.



reddot winner 2023



DESIGN  
AWARD  
2023

**HEATPEX**  
**ARIA**  
**VITALE**



**HEATPEX Sp. z o.o.**  
ul. Chrzanowskiego 11  
80-278 Gdańsk, Poland  
tel.: +48 661 693 697  
e-mail: sales@heatpex.pl

> **heatpex.pl**

## DISCOVER ARIA VITALE

